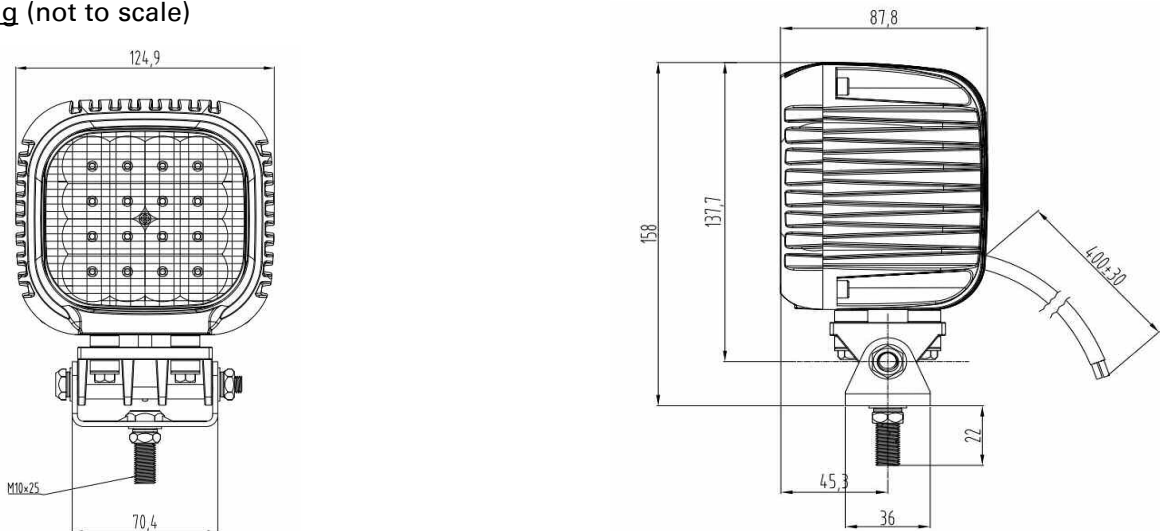

Technical Information Sheet**Part No. 0-420-77**

A powerful 16 x 3 watt 10-30 volt CREE LED Spot Lamp. Black powder coated die cast aluminium case, polycarbonate lens, supplied with stainless steel bracket. Protected to IP67. I 88 x w 125 x h 180mm. Approx Life: 50,000 hours.

**Technical Drawing (not to scale)****Specification**

Type	LED Spot lamp
Voltage	10-30 volt dc
LEDs	CREE 16 x 3W (6000K)
Light Output	3800Lumen Approx
Housing	Die cast aluminium
Bracket	Stainless steel
Lens	Polycarbonate PMMA
Degree of protection	IP67
Operating temperature	-40°C to +60°C
Weight	1.63KG
Dimensions	I 88 x w 125 x h 180mm

The information contained in this document is correct to the best of our knowledge at the time of printing. However, specifications may change at any time without notice.